

UCHIDA

AeroCut nano

OPERATION MANUAL

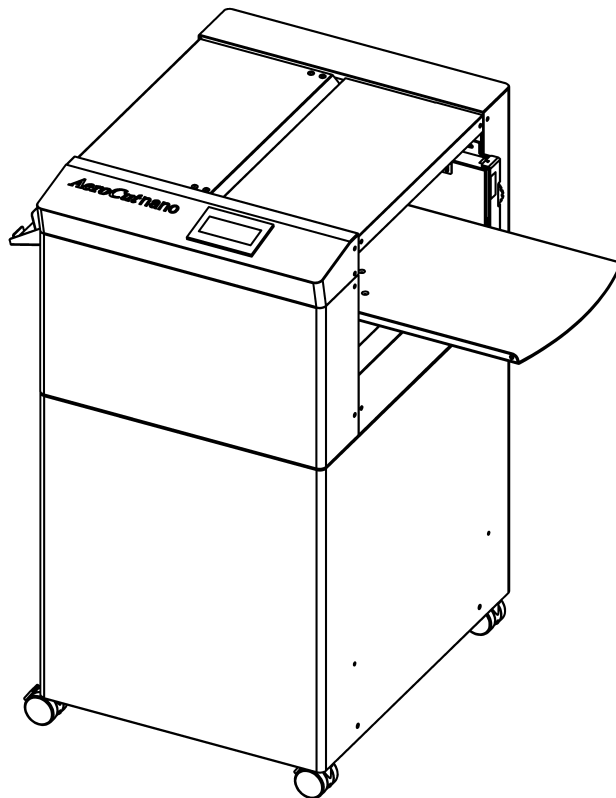

UCHIDA YOKO CO., LTD., TOKYO, JAPAN

77-872 US V1.01

- Use machine only after reading the "Safety Instructions" given below carefully.
- These safety instructions are given to ensure that the machine will be used safely and properly and to prevent operators from sustaining harm and injuries.

Definition of Symbols and Notes

In this manual the following names and signs stand for possible dangers.



Danger

This symbol stands for immediate danger threatening the life and health of persons. Disregarding these instructions may cause severe damage to health and even serious injuries.



Caution

This symbol stands for an endangering situation that may occur. Disregarding these instructions may lead to slight injuries or damage to property.



Note

This symbol stands for notes, operational hints, and other useful information.

They are convenient for exploiting the machine's functional abilities.

SAFETY INSTRUCTIONS

Explanations of the illustrations used in the Safety Instructions are given as follows:

 Danger
1. Don't open the cover of the equipment. There is a danger of receiving an injury or electric shock.
2. Don't touch any rotating part. There is a danger of receiving an injury.

 Caution
1. Don't put a hand into the cover or a clearance between parts. There is a danger of receiving an injury.
2. Don't bring a hand, face, hair, sleeves of clothes and the like close to the rotating parts of the machine. There is a danger of receiving an injury.

3. Don't touch the blade point of the cutter. There is a danger of receiving an injury.
4. Turn off the power supply beforehand when setting the feed table. There is a danger of receiving an injury.
5. Turn off the power supply beforehand when removing paper scraps. There is a danger of receiving an injury.
6. Do not exceed the MAX level when stacking the paper. Exceeding it may cause a mechanical failure.
7. Turn off the power supply beforehand when starting maintenance or inspection. There is a danger of receiving an injury.
8. When you install a machine, please install to a place with no dust, and the place which is not influenced with a liquid. It becomes the cause of failure if the installation method is mistaken.
9. When you put a machine into operation, please change into the state where all covers were closed. If it works where a cover is opened, there is fear of an injury.

Before use

Read this "Operation Manual" carefully before use. In particular, be sure to read "Safety Instructions" (page 2 to page 3) to ensure that the machine will be used properly.

Keep the manual at an appointed place with care so that it may be accessible whenever necessary.

The specifications of this product are subject to change for improvement. Therefore, don't mistake the "Operation Manual" of one product of the same model for that of another because descriptions in the "Operation Manual" of products of the same model may differ.

Contents

1	Introduction.....	6
1.1	Names of parts.....	6
1.2	Accessories.....	6
1.3	Touch panel.....	7
1.4	Paper weight / quality.....	7
2	Operating instructions	8
2.1	Lock a caster brake.....	8
2.2	Turning the power on.....	8
2.3	Input	9
2.4	Gauge (InstaSet bar) setting.....	10
2.5	Paper setting.....	11
2.6	Stacker and Waste box settings.....	12
2.7	Start	13
2.8	Stop	13
2.9	Waste disposal.....	13
2.10	Power off	14
3	Adjustment	15
3.1	Speed change.....	15
3.2	Skew adjustment.....	15
3.3	Adjustments on the paper feed section.....	16
3.4	Feed size adjustment.....	17
3.5	Slit position adjustment.....	17
3.6	Cutting location adjustment (Guillotine).....	17
4	Cut pattern input.....	18
4.1	Outline	18
4.2	PRESET	18
4.3	MANUSET/ SAVE.....	19
4.4	User program selection.....	22
5	Manual control.....	23
5.1	Manual control screen.....	23
5.2	Paper jam	23
6	Error messages	24
7	Troubleshooting.....	27
8	Product specifications	29

1 Introduction

1.1 Names of parts

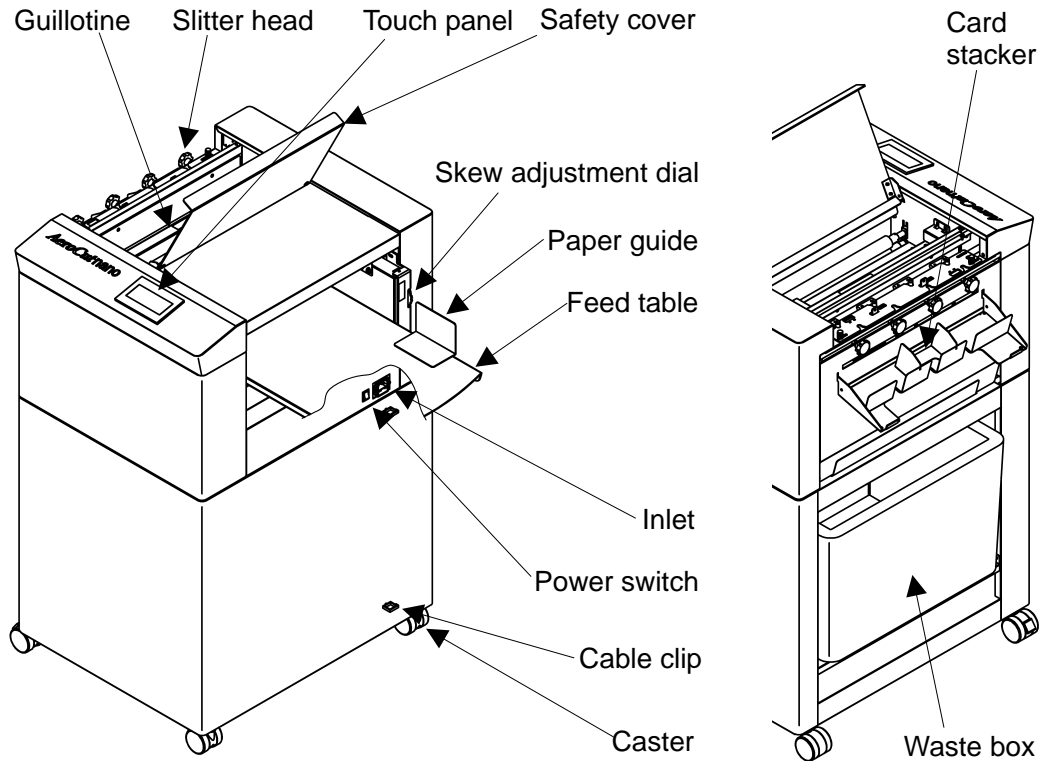

1.2 Accessories

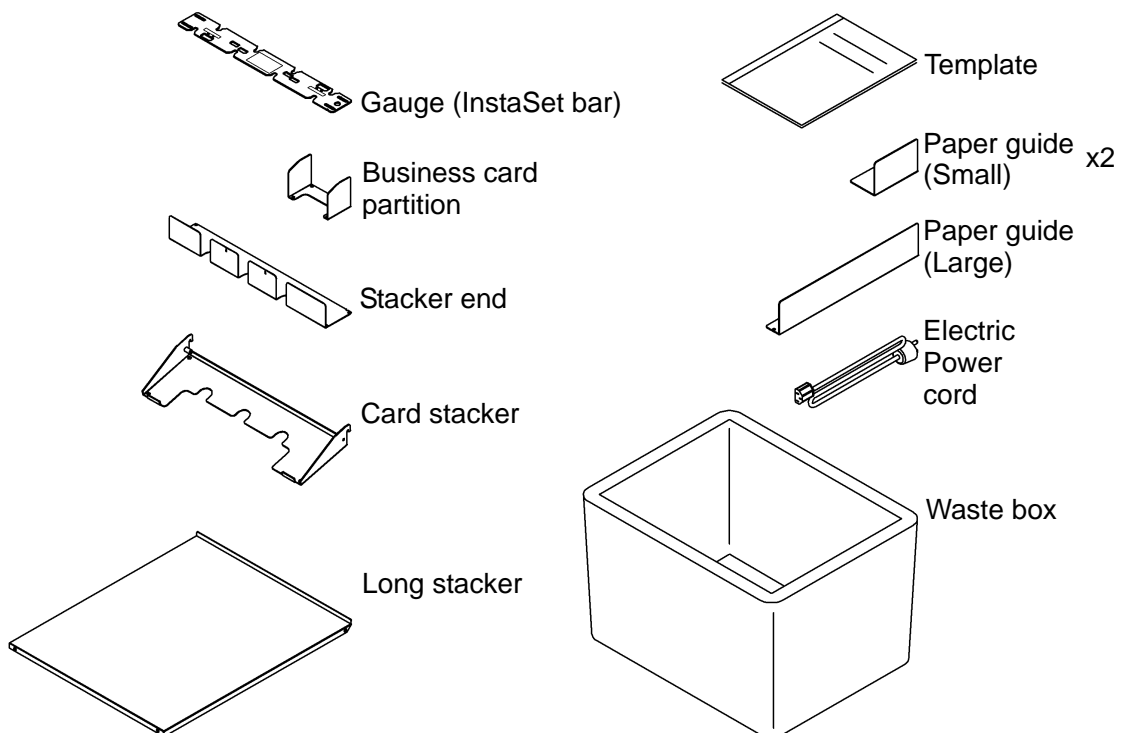

1.3 Touch panel

Home screen

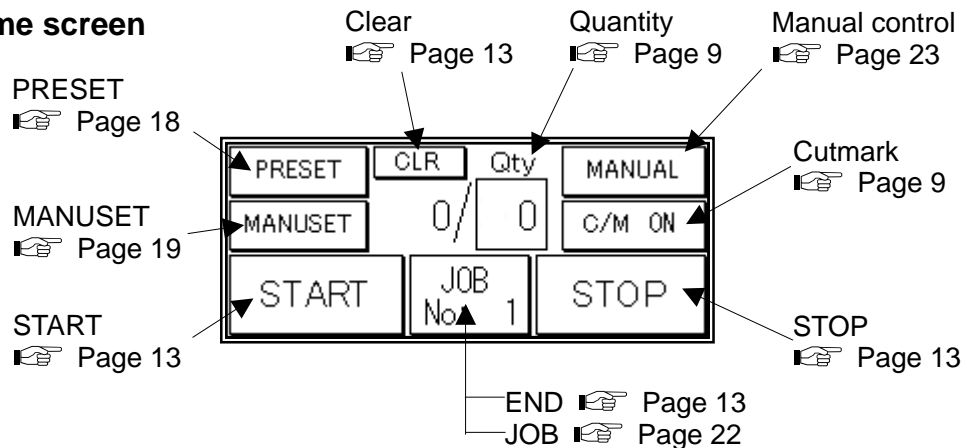

MANUSET screen

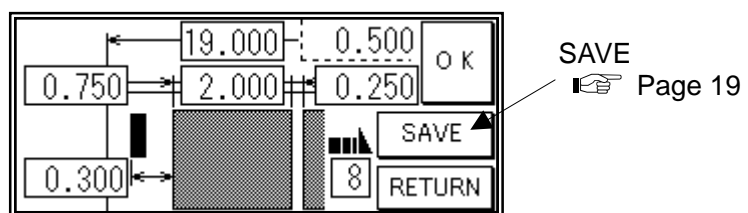

Manual control screen Inching

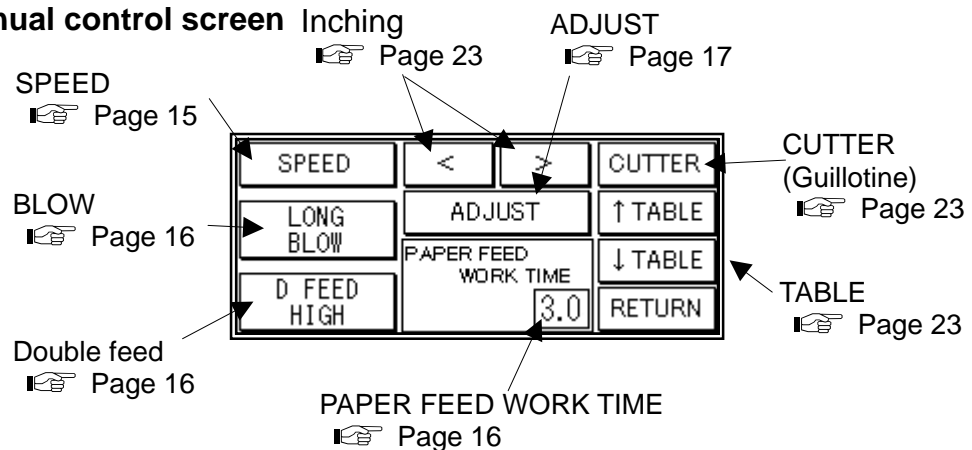

1.4 Paper weight / quality

Use suitable paper stocks which weight is

32 lbs (Bond) - 130 lbs (Cover stock)[120-350g/m²].

These paper stocks are not suitable in use.

- Papers that has heavily electric static charged. It may cause miss-feed, double feed or paper jam.
- Papers that are more than 0.125" curled or waved. It may cause miss-feed, double feed or paper jam.
- Papers that have ink or toner not fused properly. It may cause contaminating the work and the machine.
- Papers that are too slippery. It may cause miss-feed or inaccurate results.
- Prints that are shrank, stretched or skewed inconsistently. It may cause inaccurate results.

2 Operating instructions

2.1 Lock a caster brake

2.2 Turning the power on

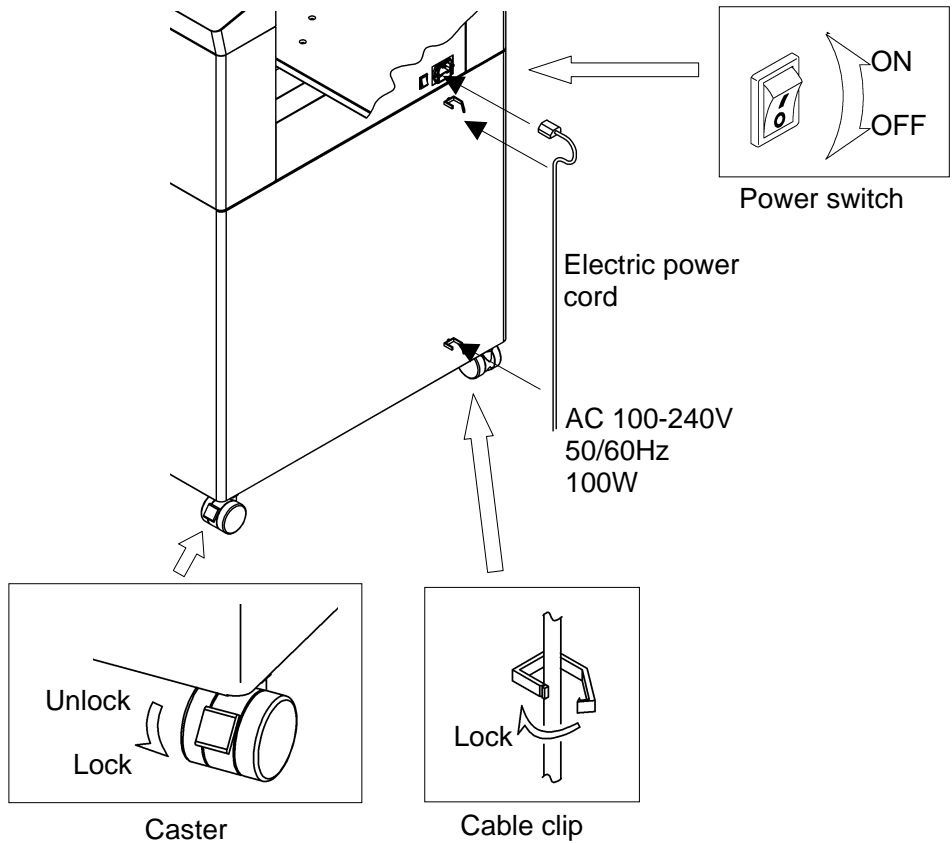

Power on



Opening screen



Home screen

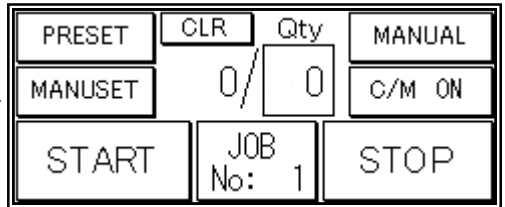

2.3 Input

- ① Enter the cut pattern.  Page 18

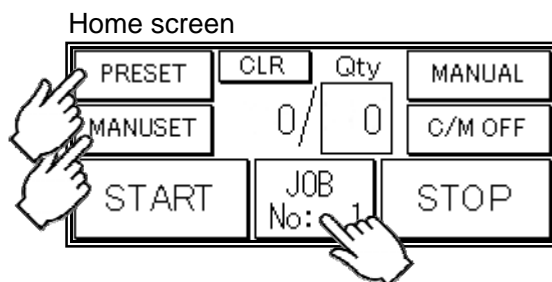

- ② Enter the number of sheets for operation.

All the sheets on the feed table will feed in case 0 is entered in Qty.

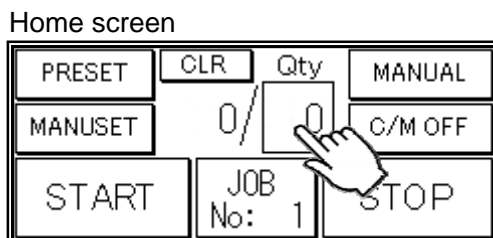

- ③ Touch the screen to have C/M ON to activate cut-mark registration.

When it is on, the machine register the cut-mark and cross cuts at proper positions even the image is drifted.

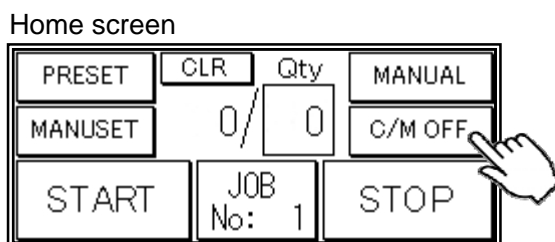

Note.

Cut-mark sensor detects the black mark by infrared light.

Some types of toner or ink may reflect the infrared light and cause the sensor not reading the cut-mark. Please inactivate the cut-mark registration in such cases.

2.4 Gauge (InstaSet bar) setting

- Select the right InstaSet bar according to desired cut pattern.

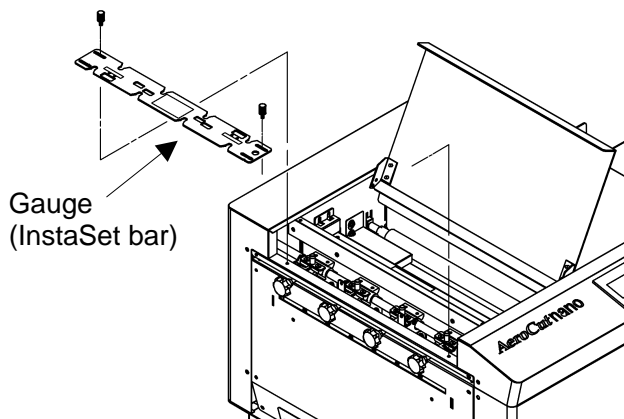

- ① Loosen the slitter head lock knobs.
- ② Slide the slitter head with holding the knob.

Adjust the positions of the slitters so that their pins fit to the U-notches on the InstaSet bar. Snap the InstaSet bar with the labeled side on top and adjust it so that its pointer points 0.

- ③ Tighten the screws.
- ④ Tighten the slitter head lock knobs.

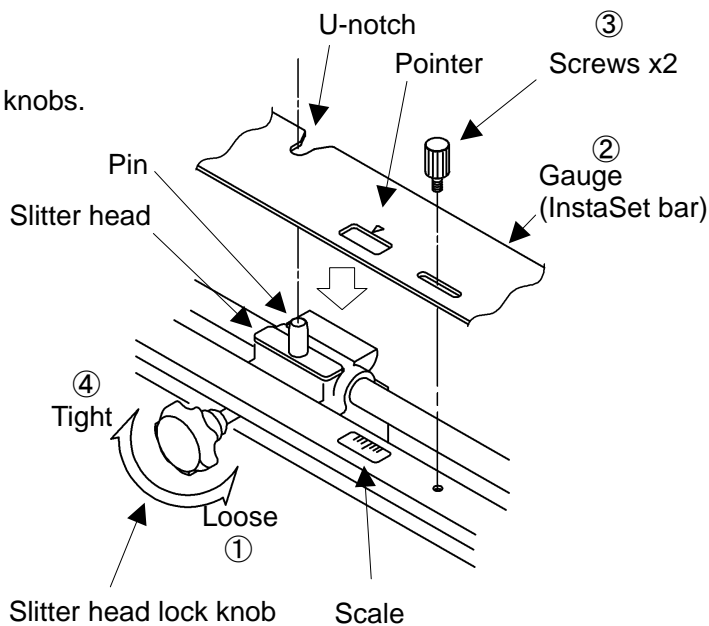

- Some cut patterns do not require to use all the slitter units.

In such cases, slide the unnecessary slitter head(s) to side trench and tighten the slitter head lock knob(s).

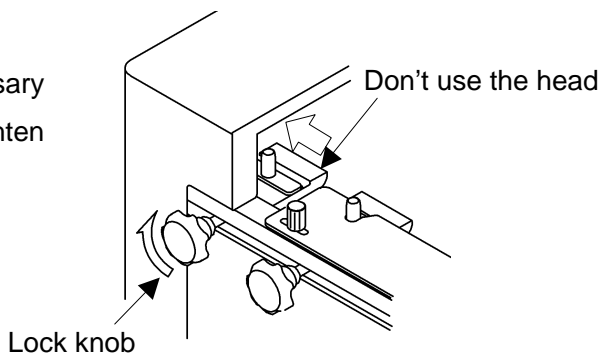

2.5 Paper setting

- ① Press the START button on the home screen (☞ Page 7) if the feed table is in upper position. The feed table moves down to the lower dead point.
- ② Flip through the sheets well before you put them on the feed table.
- ③ Set the sheets on the feed table. Use the pager guide (Large) and paper guides (Small) to fix the sheets.

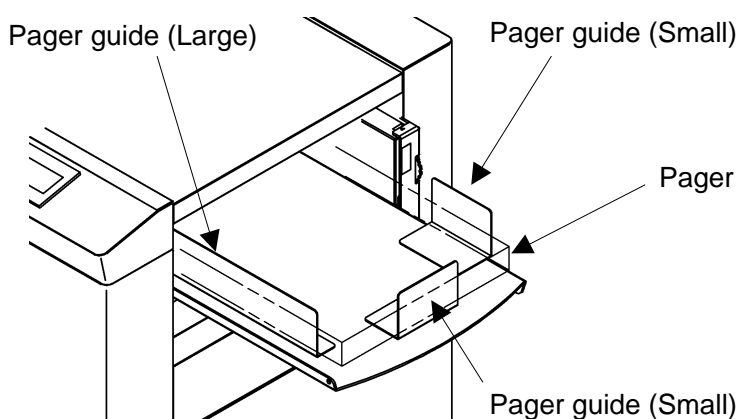
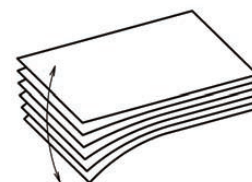

- Paper loading capacity is 1.2”.
- Make sure that the paper stack does not exceed the MAX label.
- It affects finishing accuracy if there is a gap between the side guide and the sheets.

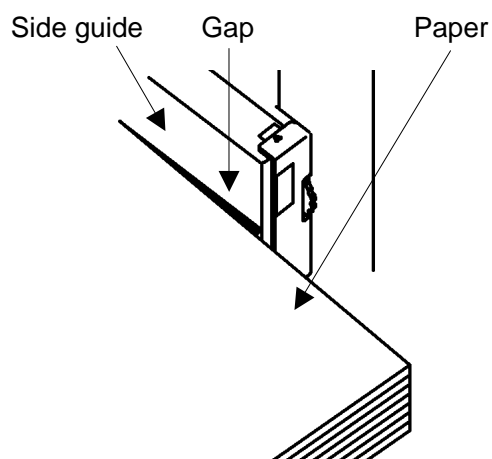

- If the print is skew on the sheets, the angle of the side guide can be adjusted. (☞ Page 15)

2.6 Stacker and Waste box settings

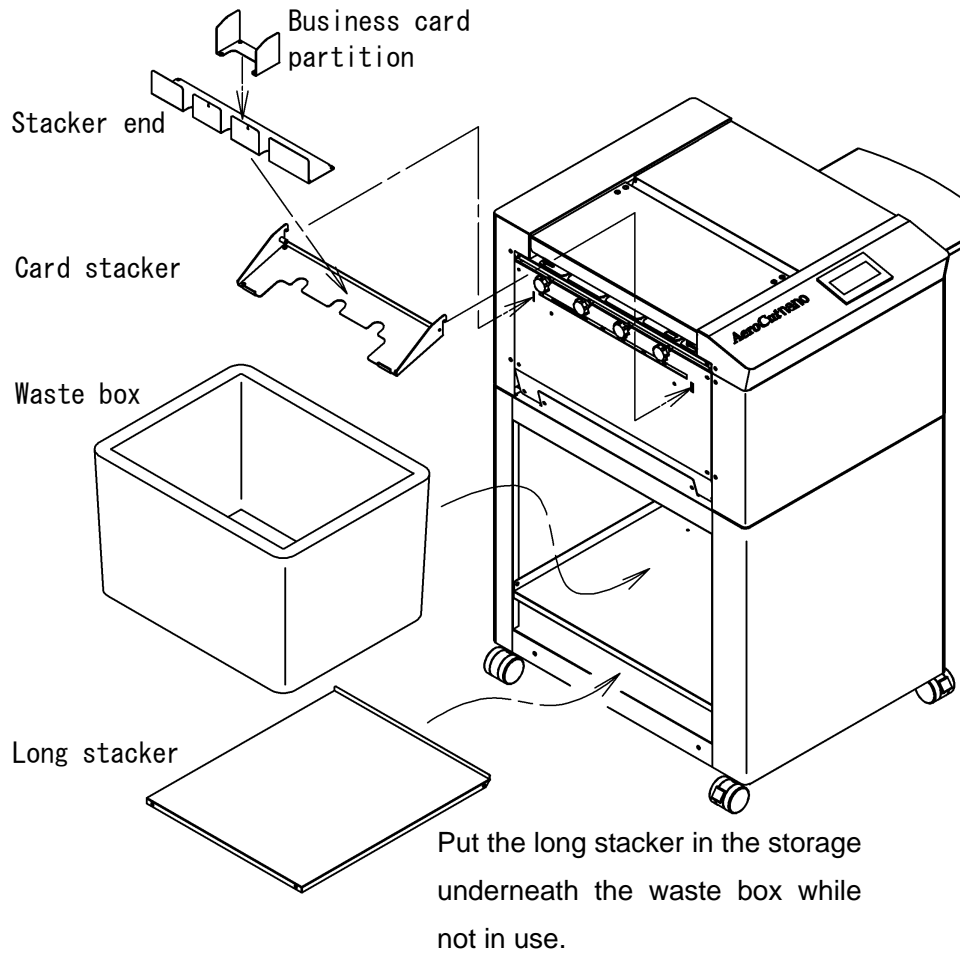

- Change the settings of the stacker according to the cut pattern.

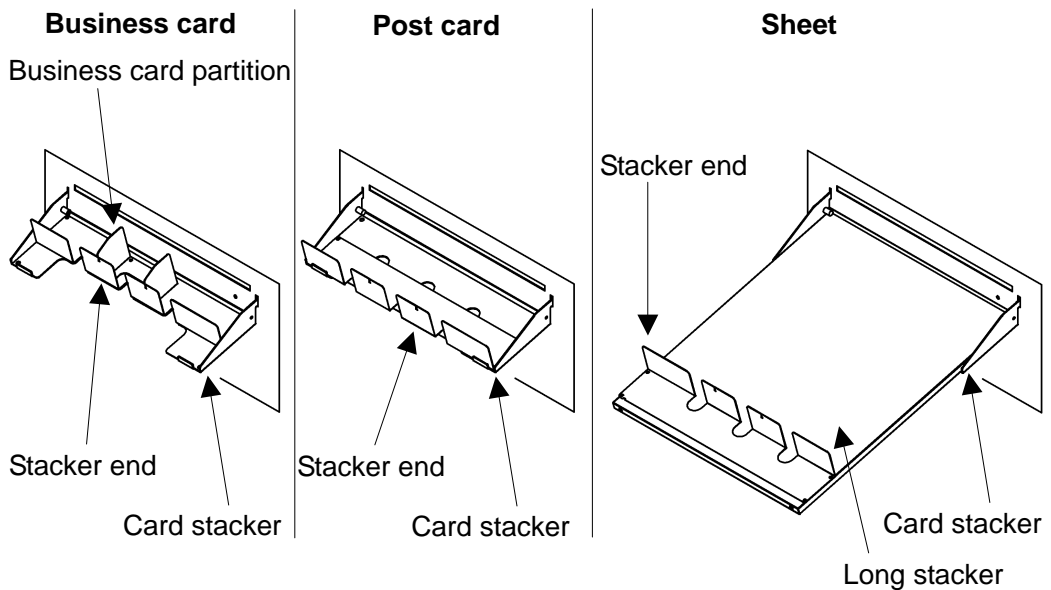

2.7 Start

Home screen

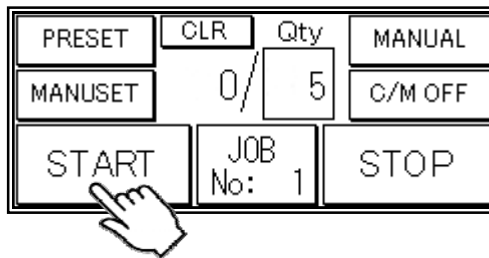

- After processing the entered number of sheets in Qty, the machine stops automatically.
- Do not open the Safety cover (☞ Page 6) while the machine is running. Machine will stop immediately.

2.8 Stop

Home screen (While Running)

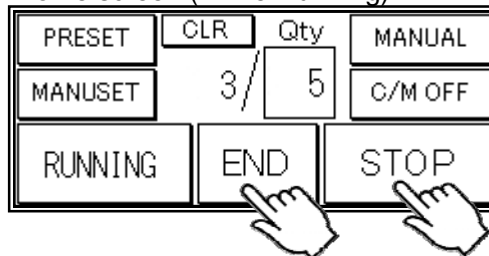

- Press STOP and the machine will make an EMERGENCY stop even if the operation is underway.
- Press END if you wish to stop the machine when the current sheet is completed.
- The counter indicates the number of finished sheet when the machine is stopped with STOP or END button. Press CLR to reset the counter to 0.

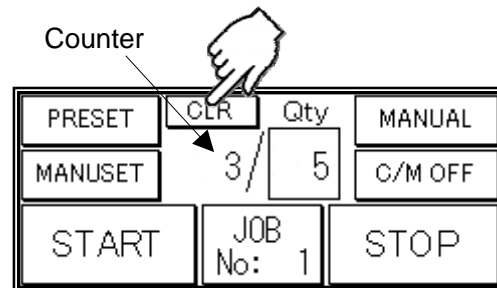

- If paper is left in the machine, remove it by inching. (☞ Page 23)

2.9 Waste disposal

- Dispose the wastes in the waste box appropriately.
- Overloading wastes causes errors or a breakdown.

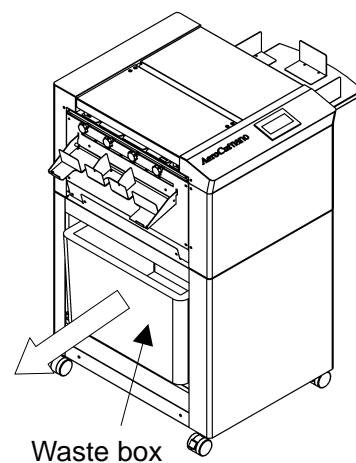

2.10 Power off

- Make sure that the machine is stopped.
- Return to the Home screen.
- Turn off the Power switch.

Home screen

PRESET	CLR	Qty	MANUAL
MANUSET	0/	5	C/M OFF
START	JOB No: 1	STOP	

3 Adjustment

3.1 Speed change

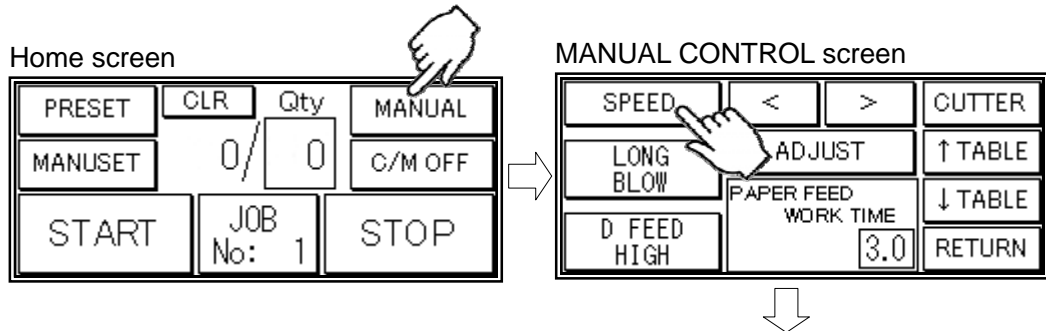

- In case of finishing thick paper, slow down the speed.
- If finished sizes are inaccurate or inconsistent, there is a possibility that the running speed is too fast. Slow down the speed.

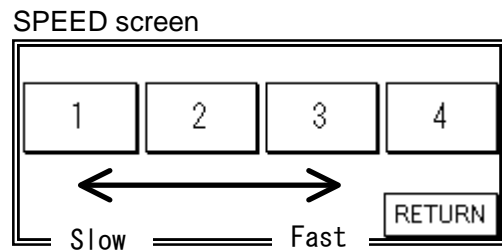

• Note. The reference of the paper thickness and speed.

- 0.006" (0.15mm)	4
0.006" - 0.01"(0.25mm)	3
0.01" -	2

3.2 Skew adjustment

- If print is skew on the sheet, the angle of the side guide can be adjusted.
- The angle of the side guide changes as the skew adjustment dial is turned.

Set the sheets again. Page 11

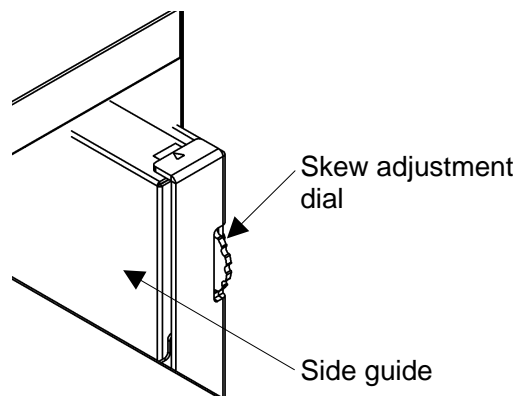

3.3 Adjustments on the paper feed section

- Adjustments are required when the machine is likely to feed double or skew.

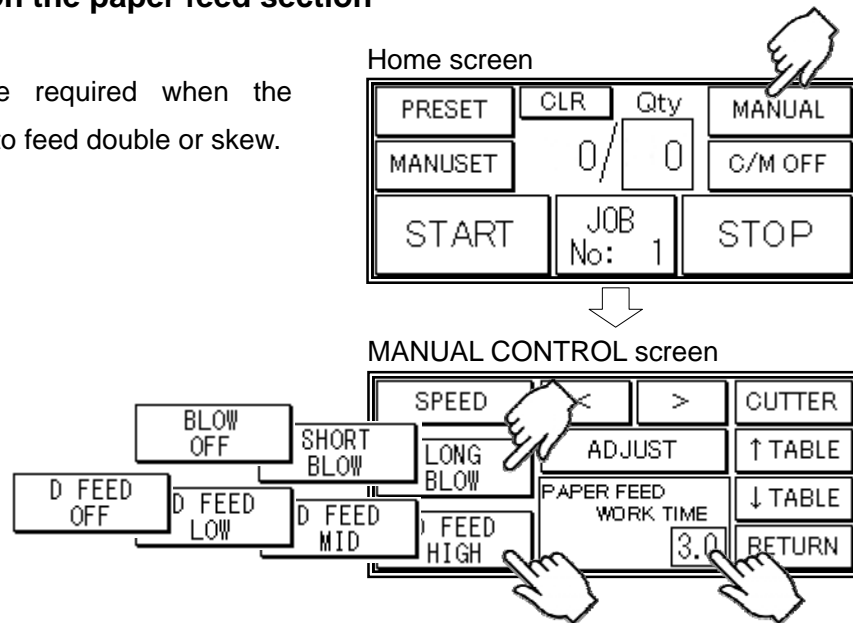

- Air blow adjustment

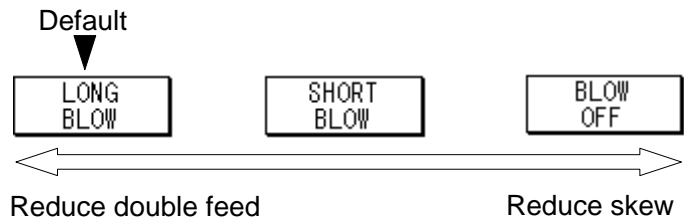

- PAPER FEED WORK TIME adjustment

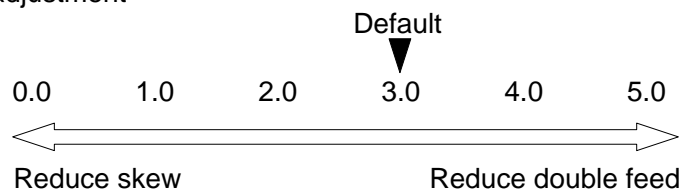

- Sensitivity of Double feed sensor



- If the machine detects double feed even with a single sheet, lower the sensitivity of the detection sensor.
- The detection sensor detects double feed by checking the edge of sheets as shown on the drawing. It is recommended not to print on the sheet edge.

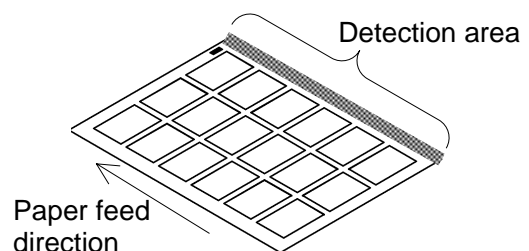

3.4 Feed size adjustment

- Adjust through MANUSET screen.

Page 19

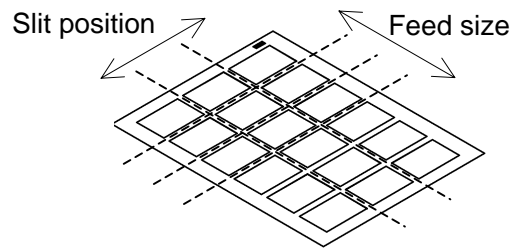

3.5 Slit position adjustment

- Adjust the positions of the slitter heads by moving the gauge (InstaSet bar).
- The gaps between the slitter heads are not adjustable.

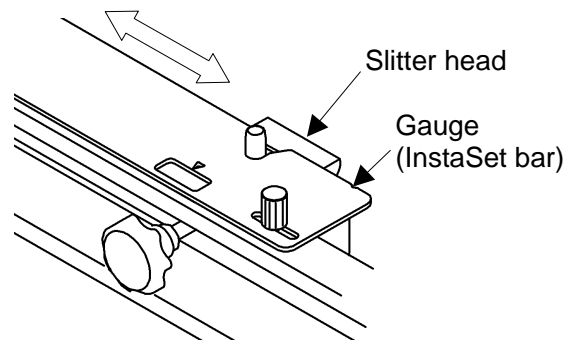

3.6 Cutting location adjustment (Guillotine)

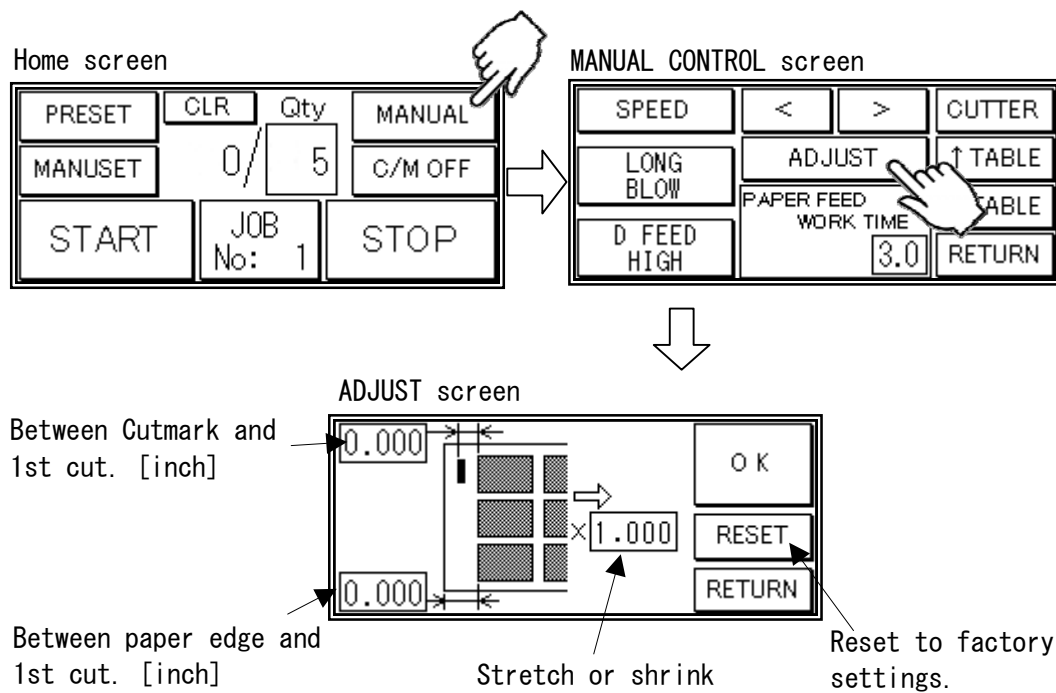

Input balance between the entered value in MANUSET and the actual finished size.
 i.e. MANUSET:1.00", Actual size:1.02" = Input -0.02"

4 Cut pattern input

4.1 Outline

- PRESET PRESET is a series of cut patterns that are already stored in the machine. (☞ Template)

- MANUSET In MANUSET mode, user programs can be created and stored into the machine.

- JOB No: 1 Recall the stored user programs.

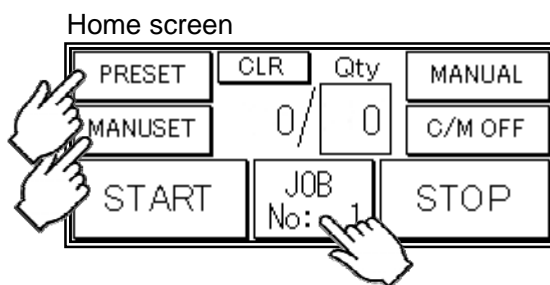

4.2 PRESET

- ① Press PRESET.

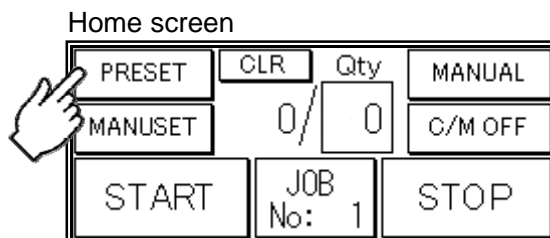

- ② Press the size of the original sheets.

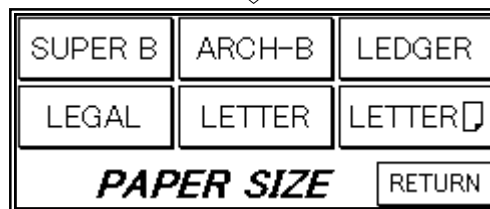

- ② Press the cut size.



- ③ The machine recalls the preset pattern and automatically returns to the home screen.

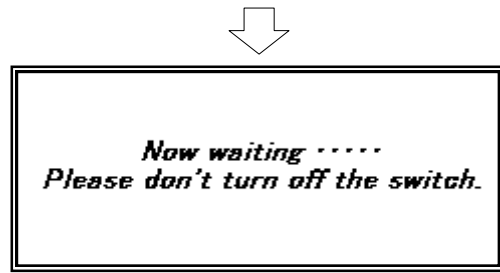

- ④ To check the details of selected job, press the MANUSET. Press the START to get the machine started.

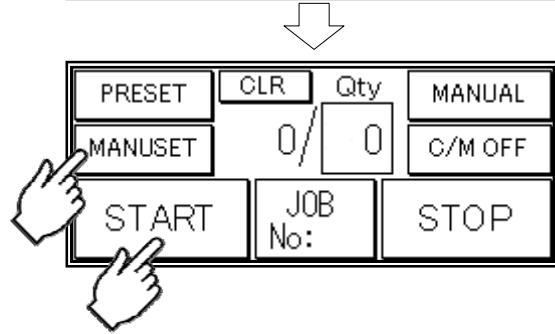

4.3 MANUSET/ SAVE

- ① Press MANUSET.

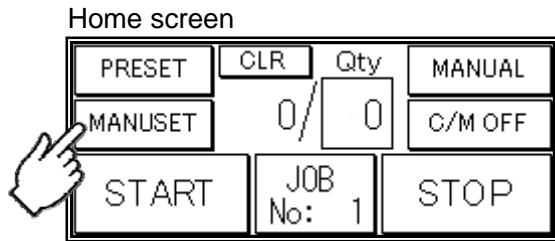

- ② The screen displays the current cut pattern. The program shown in the picture is for the below cut pattern.

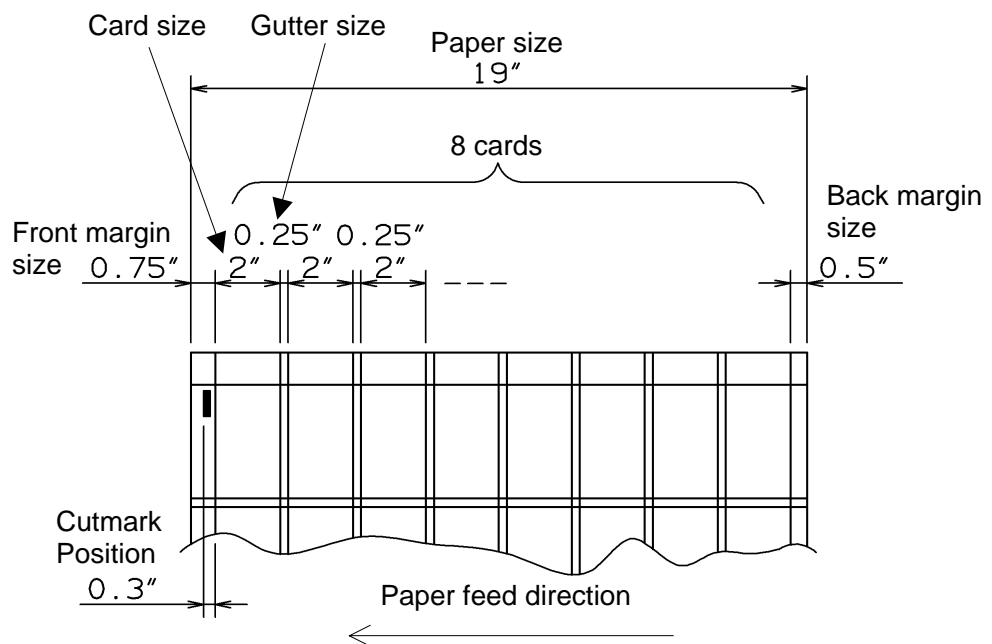
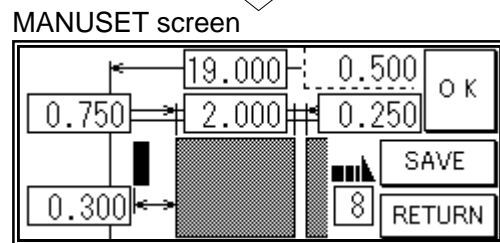

- ③ Press the number to change the value.

The values that can be changed and the limits are as shown in the figure below.

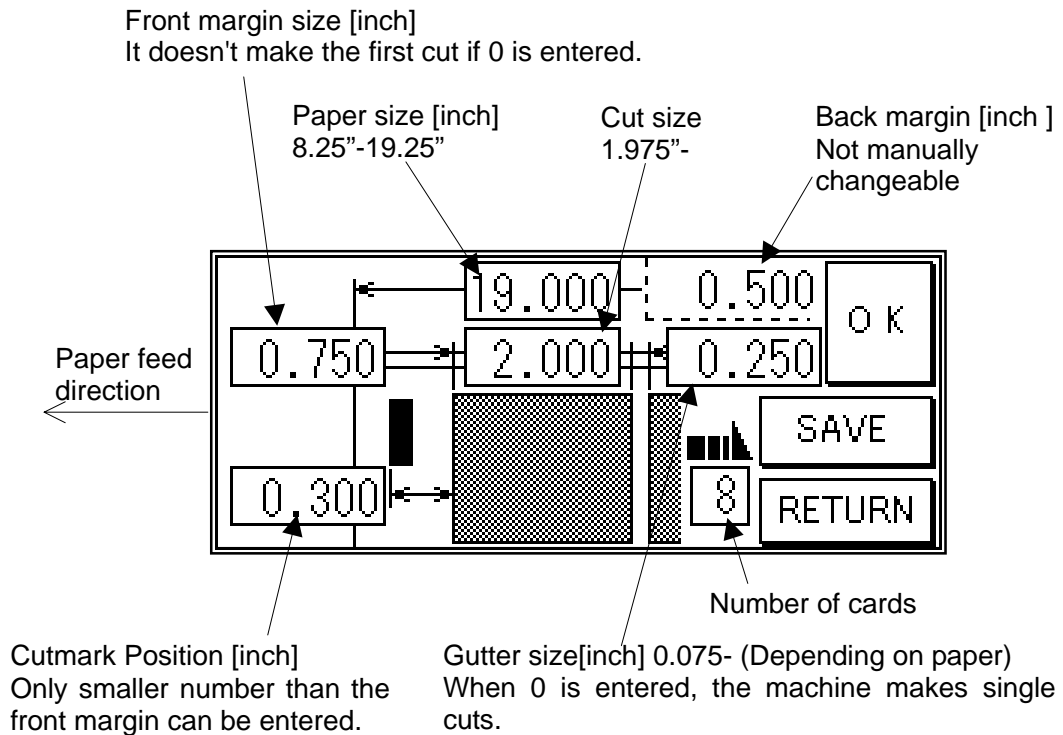

- If an error message is displayed. Page 24

- ④ Can store the contents of the MANUSET Press the

40 user program can be registered.

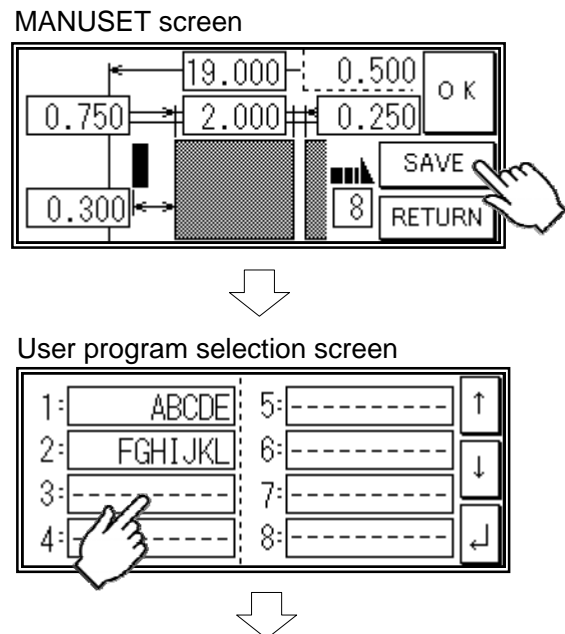

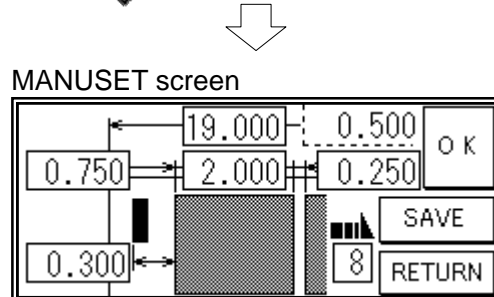
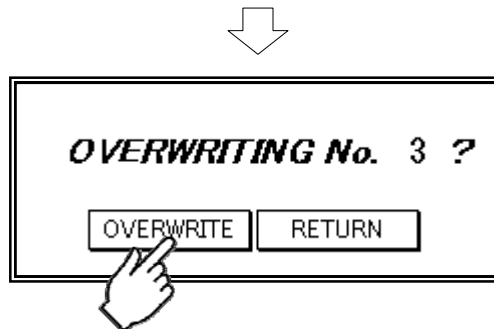
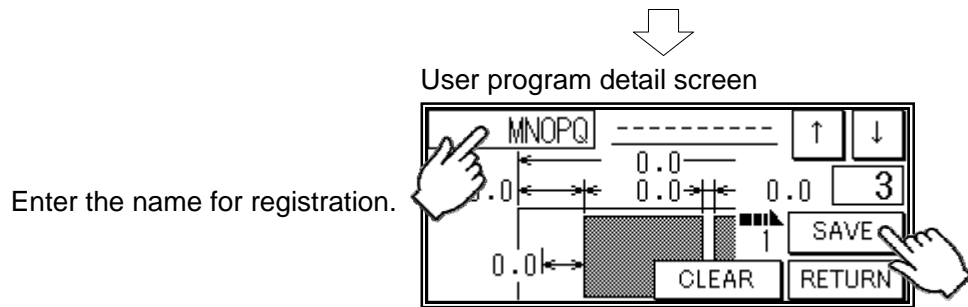

Note.

Press to delete the user program.

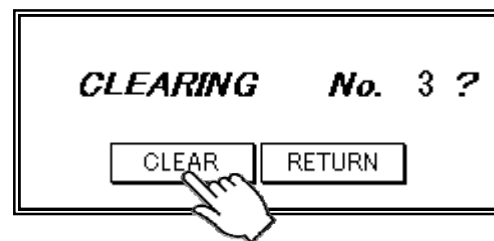
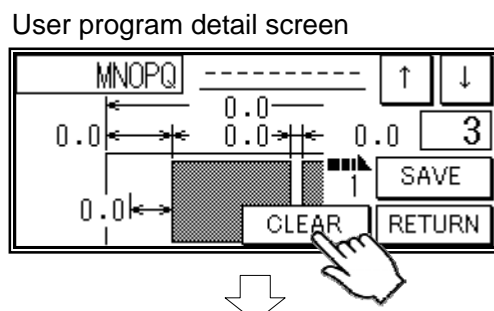

4.4 User program selection

Home screen

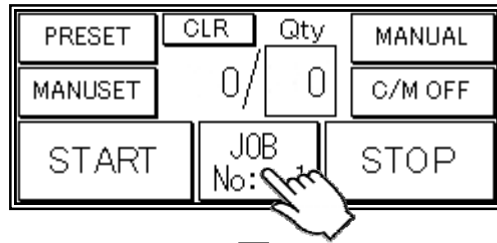

User program selection screen

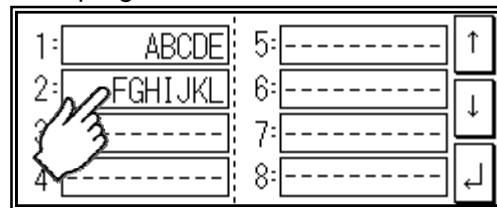

User program detail screen

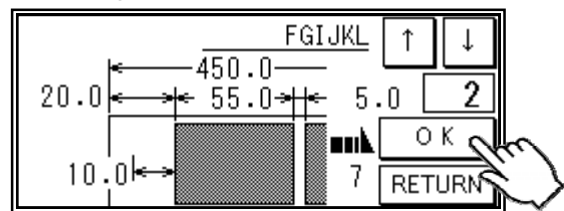

Home screen

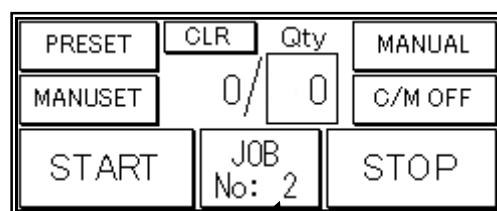

The screen indicates the user program number.

5 Manual control

5.1 Manual control screen

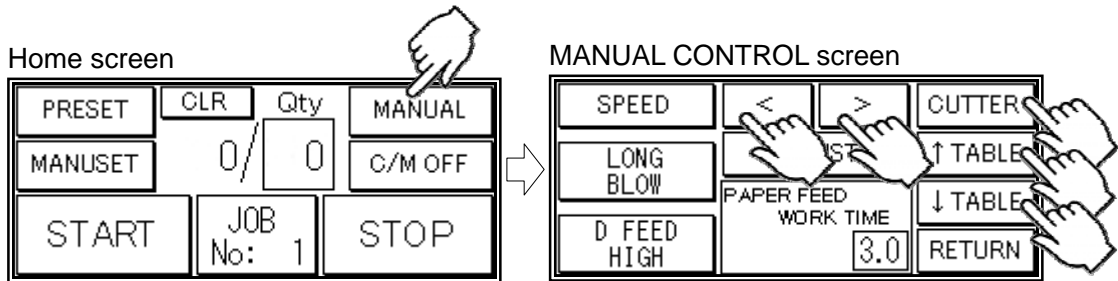

- Feed roller will rotate.
Inching
- Guillotine will move once.
-
- Feed table will move.

5.2 Paper jam

- ① Enter MANUAL CONTROL screen, press < > buttons to inch the rollers forward/backward and remove the jammed paper.
If paper is stuck around the guillotine section, press CUTTER to cycle the guillotine to chop jammed paper.

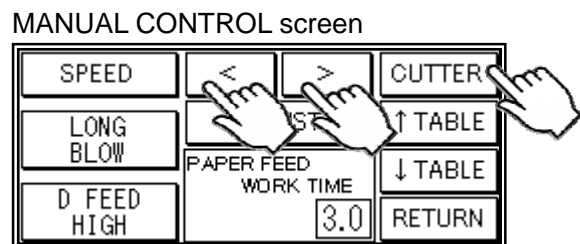

- ② If the Main motor doesn't rotate, slow down the speed.

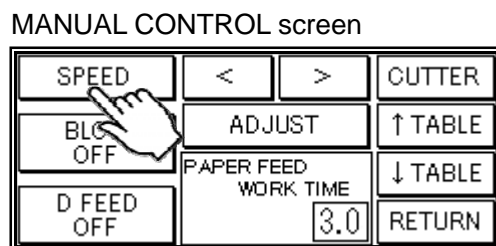

6 Error messages

1.

***COVER OPEN !!
CLOSE COVER.***

Safety cover (👉 Page 6) might be open.
Make sure to close the Safety cover closed.

2.

***TIME OUT ERROR !!
CHECK PAPER PATH.***

RETURN

Timeout error 1
Paper was not fed within a set time period.
Check the paper feeder.

3.

***TIME OUT ERROR !!
CHECK PAPER PATH.***

<

RETURN

>

Timeout error 2
Paper did not pass through within a set time period.
Remove the paper remaining inside the machine.

4.

DOUBLE FEED DETECTED !!

<

RETURN

>

Check the paper or paper path.

5.

***CUT-MARK NOT READ !!
CHECK CUT-MARK
or SENSOR!!***

<

RETURN

>

Cutmark was unable to be detected.
Check the cut mark.
Eject the paper inside the machine.

Note.
Cut-mark sensor detects the black mark by infrared light. Some types of toner or ink may reflect the infrared light and cause the sensor not reading the cut-mark. Please inactivate the cut-mark registration in such cases.

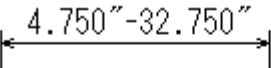
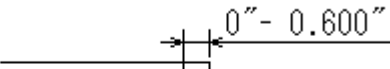
- | | | |
|-----|---|--|
| 6. | <p><i>CUT PAPER JAMMED !!</i>
 <i>REMOVE JAMMED PAPER.</i></p> <div style="display: flex; justify-content: center; gap: 10px;"> < RETURN > </div> | <p>Paper remains inside the machine.
Remove the paper.</p> |
| 7. | <p><i>OVERLOADED !!</i>
 <i>CHECK KNIFE UNIT !!</i></p> <div style="display: flex; justify-content: center; gap: 10px;"> RETURN </div> | <p>Overload error 1
Cutting did not complete within a set time period.
Remove the paper remaining inside the machine.</p> |
| 8. | <p><i>OVERLOADED !!</i>
 <i>CHECK PAPER FEED TABLE !!</i></p> <div style="display: flex; justify-content: center; gap: 10px;"> RETURN </div> | <p>Overload error 2
An overloading error occurred at the feed table.
Check the feed table.</p> |
| 9. | <p><i>COMMUNICATIONS ERROR!!</i>
 <i>Cut off the power supply!</i>
 <i>ERROR CODE: -*****</i></p> | <p>Communication with the touch panel is not possible.
Turn off the power, and turn it on again after 5 seconds or longer.</p> |
| 10. | <div style="display: flex; align-items: center; justify-content: center;"> <div style="text-align: center; margin-right: 10px;"> <p>4.750" - 32.750"</p>  </div> <div style="border: 1px solid black; padding: 5px; margin-left: 10px;">RETURN</div> </div> | <p>Paper size error
Correct the paper size to fit in the value range below.</p> |
| 11. | <div style="display: flex; align-items: center; justify-content: center;"> <div style="text-align: center; margin-right: 10px;"> <p>0" - 0.600"</p>  </div> <div style="border: 1px solid black; padding: 5px; margin-left: 10px;">RETURN</div> </div> | <p>Back margin error
Correct the back margin to fit in the value specified below.</p> |

12.

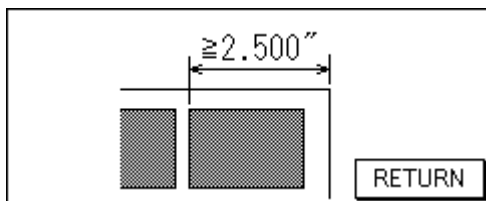

Final cutting measurement error
Correct the final cutting measurement to exceed the value specified below.

13.

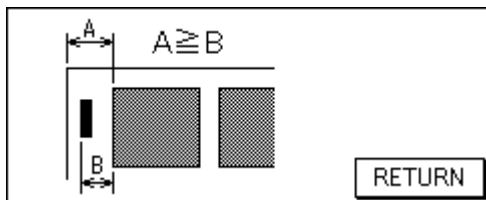

Leading edge margin and cut mark margin warning
Correct the measurement so that the leading margin becomes larger than the cut mark margin.

14.

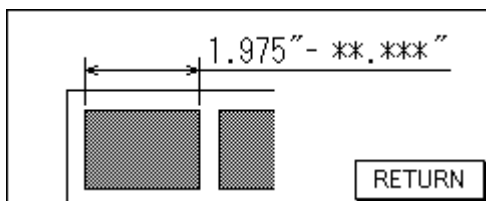

Cutting measurement error
Correct the cutting measurement to fit in the value range below.
The maximum value is subject to change depending on the entered paper size.

15.

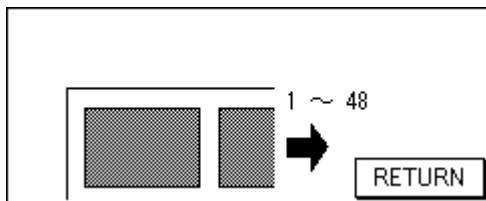

Cut piece number error
Correct the number of cut pieces to be in the value range below.
The maximum number of pieces is subject to change depending on the operation.

7 Troubleshooting

1. Papers are not fed well.

- Check if the paper guides on the feed table hold sheets too tight.
- Make sure that the paper edges are not curled or waved.
- Make sure that the papers are not heavily electric static charged.
- Shorten the PAPER FEED WORK TIME. i.e. 1.0 (👉 Page 16)
- Lengthen the air blow adjustment. (👉 Page 16)

2. The machine feeds double-sheets.

- Make sure that the papers are not heavily electric static charged.
- Lengthen the air blow adjustment. (👉 Page 16)
- Lengthen the PAPER FEED WORK TIME. i.e. 3.0 (👉 Page 16)

3. The machine doesn't detect double-feed properly.

- The machine detects the density of the first fed sheet and compares the density of the next sheet to the first one. Therefore, the machine cannot detect double-feed when it occurs with the first fed sheet.
- Adjust the sensitivity of the double-feed detection sensor. (👉 Page 16)
- The detection sensor detects double feed by checking the edge of sheets as shown on the drawing. It is recommended not to print on the sheet edge. (👉 Page 16)

4. The machine detects double-feed mistakenly.

- Adjust the sensitivity of the double-feed detection sensor. (👉 Page 16)
- The detection sensor detects double feed by checking the edge of sheets as shown on the drawing. It is recommended not to print on the sheet edge. (👉 Page 16)

5. Cut skewing

- ① Make sure that the stock is put on the feed table correctly. (👉 Page 11)
- ② Check whether the skewings are consistent or inconsistent.

If skewings are consistent :

- + Make the skewing adjust via the skew adjustment dial. (👉 Page 15)
- + Set the paper guides without play.

Do not set them too tight as the sheet may not be fed well.

If skewings are inconsistent :

- + Make the blower and separation time adjustments properly. (👉 Page 16)
- + Make sure that the sheets are printed consistently and aligned well.

6. Paper jam often occurs.

- Make sure that papers, paper strips or paper dusts not remain inside of the machine.
- Check the conditions of the paper stock. (👉 Page 7)

8 Product specifications

Specifications	
Slitter	4 sets (6 slitter blades)
Guillotine	1 set
Maximum paper size	13" x 19"
Minimum paper size	8.25" x 8.25"
Minimum work size	3.5" x 2"
Paper weight	32 lbs (Bond) – 130 lbs (Cover stock) (120-350g/m ²)
Maximum paper curl size	0.125"
Paper type	Offset, Coat, UVcoat, Glossy, Laminate
Paper feeding method	Air Suction
Input tray capacity	MAX1.2"
Speed	6 sheets per minute (21 business cards from A3)
Machine dimensions	W22.2"x D24.9"x H37.9" (Occupancy area: W46.9"x D24.9"x H46.5")
Net weight	154lb (70kg)
Power supply	Single phase 100- 240VAC, 50/60Hz,
Power consumption	100W
Use temperature	-5°C~+40°C
Preservation temperature	-25°C~+65°C
Use temperature humidity	45~85%RH
Preservation humidity	25~100%RH
Use the uplands	~1000M
One's tolerance level	100~240V +6%, -10%
Over voltage category	Category II according to IEC60664-1
Pollution degree	Degree 3 according to IEC60664-1

Keep this “Operation Manual” at an appointed place with care so that it may be available whenever required.

If this “Operation Manual” is stained or lost, make contact with the distributor or our salesman or customer service section to ask for a new operation manual after making sure of its contents.

When ordering consumables or parts, be sure to specify the machine model.